

---

## Arduino Based Faculty Locator Using Rfid

Pawan Gorde<sup>\*1</sup>, Akshay Chincholkar<sup>2</sup>, Pratiksha Chaudhari<sup>3</sup>, Nidhi Patil<sup>4</sup>

UG Student- Electronics and Telecommunication G. W. College of Engineering, Salai Godhni, Chikna Village Nagpur

---

**Abstract:** In global perspective, it is a difficult job to contact human beings in big institutions in spite of the prohibition in mobile network. Presently, global system positioning and Zigbee are employed in locating and tracking. But these are expensive. Previous analysis and development for indoor localization includes infrared, wireless LAN etc., But these suffers from limited accuracy. On the other hand, there is a growing interest in RFID technology. It is often leveraged to locate staff in a reasonable, power efficient and user friendly manner. Indoor location tracking system allows you to track the location with the facility of RFID tags and RFID readers. RFID is an acronym for Radio Frequency Identification and is a fast and reliable means for locating an individual. In this project, we use RFID technology with Arduino system for data transmission while locating a person in big institutions in a mobile prohibited area. A RFID tag will be provided to each person/staff member and a RFID reader is fixed in each room (classroom/ laboratories/ cabin). Person has to punch the RFID so that the information to be updated on the display unit. This will help other staff/students to easily locate the regarding faculty.

**Index Terms:** Global positioning system, zigbee, tracking, LAN, RFID, Arduino.

---

### I. Introduction:

RFID is one of potential technologies which provide real time inventory data, real-time asset, object or human tracking, control etc. A radio frequency identification technology (RFID) belongs to the fastest growing sector of the radio technology industry just because of pre mentioned applications. It enables radio detection and recognition of an objects associated with an unique ID number code carried by the RFID tag. These tags send back their unique code whenever they are interrogated by an RFID reader. These tags have integrated circuit containing the tag's ID with RF antenna.

Passive tags have no independent source of electrical power to drive its circuitry and they are depending on the received power from the reader to support operation of their circuitry and to send information back to the reader. RFID systems are distinguished by their frequency ranges. Low-frequency RFID systems operates between 30 kHz and 500 KHz and they are having shortest reading ranges and lower system costs. High frequency (13.56 MHz) RFID systems are having higher reading ranges compared to low frequency RFID systems and better reading speeds. In this expert work is presented RFID technology based system for tracking faculty in the colleges.

We developed user friendly software application for real-time tracking objects based on Alien. User can have better insight in objects usage, replacing and moving outside the room.

### II. Problem Statement

Now a days we normally see that At the time of submission, students in the colleges and faculties also have to problems to find out a particular faculty. Where there is problem of network or in the colleges where jammer is placed in the college, it is a difficult job to find out faculties, to resolve this problem we are going to make a system which can completely solve this problem. the name of system is RFID Based Faculty locator.

### III. Block Diagram

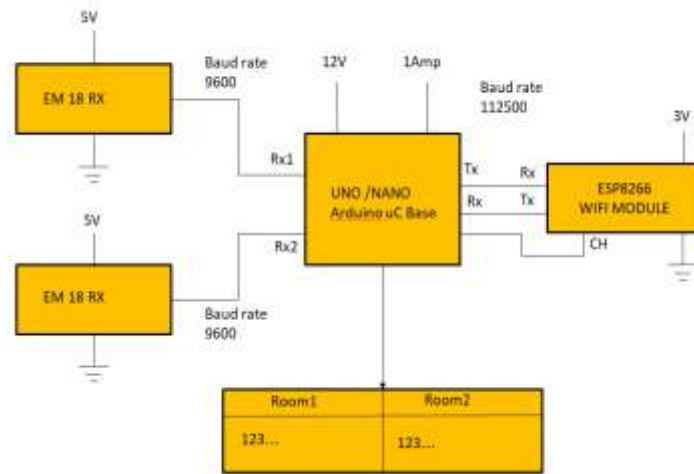

Fig (a). Block Diagram Of Hardware Structure

#### Equipment Description:-

##### A. Arduino nano

The Arduino Nano is a little, total, and breadboard-accommodating board dependent on the ATmega328P (Arduino Nano 3.x). It has pretty much a similar usefulness of the Arduino Nano, yet in an alternate bundle. It needs just a DC control jack, and works with a Mini-B USB link rather than a standard one.

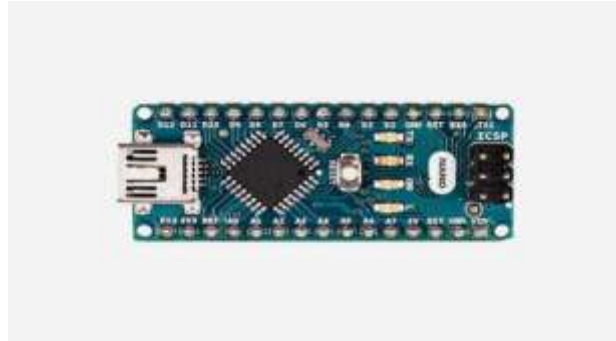

Fig I. Arduino Nano chip

##### • Arduino nano specifications:-

###### a) Power:

The Arduino Nano can be fueled through the Mini-B USB association, 6-20V unregulated outside power supply (stick 30), or 5V controlled outer power supply (stick 27). The power source is naturally chosen to the most astounding voltage source.

###### b) Memory:

The ATmega328 has 32 KB, (likewise with 2 KB utilized for the boot loader. The ATmega328 has 2 KB of SRAM and 1 KB of EEPROM.

###### c) Input and Output:

Each of the 14 digital pins on the Nano can be utilized as an input or output, utilizing pin Mode (), digital Write(), and digital Read() functions. They work at 5 volts. Each pin can give or get a limit of 40 mA and has an inside draw up resistor (disengaged as a matter of course) of 20-50 k Ohms. Moreover, a few pins have specific capacities:

**Serial:** 0 (RX) and 1 (TX). Used to get (RX) and transmit (TX) TTL sequential information. These pins are associated with the comparing pins of the FTDI USB-to-TTL Serial chip.

**External Interrupts:** 2 and 3. These pins can be arranged to trigger an interrupt on a low value, a rising or falling edge, or an adjustment in value. See the attach Interrupt () work for details.

**PWM:** 3, 5, 6, 9, 10, and 11. Provide 8-bit PWM output with the analog Write () function.

**SPI:** 10 (SS), 11 (MOSI), 12 (MISO), 13 (SCK). These pins support SPI communication, which, in spite of the fact that given by the hidden equipment, isn't as of now incorporated into the Arduino Language.

**LED:** 13. There is a worked in LED associated with advanced pin 13. At the point when the pin is HIGH value, the LED is on, when the pin is LOW, it's off.

The Nano has 8 simple data sources, every one of which gives 10 bits of goals (for example 1024 distinct qualities). As a matter of course they measure from ground to 5 volts, however is it conceivable to change the upper end of their range utilizing the simple Reference () work. Simple pins 6 and 7 can't be utilized as advanced pins. Also, a few pins have particular usefulness:

**I2C:** A4 (SDA) and A5 (SCL). Support I2C (TWI) correspondence utilizing the Wire library (documentation on the Wiring site).

**d) Communication:**

The Arduino Nano has various facilities for speaking with a PC, another Arduino, or different microcontrollers. The ATmega328 give UART TTL (5V) sequential correspondence, which is accessible on computerized pins 0 (RX) and 1 (TX). A FTDI FT232RL on the board channels this sequential correspondence over USB and the FTDI drivers (included with the Arduino programming) give a virtual com port to programming on the PC. The Arduino programming incorporates a sequential screen which enables basic printed information to be sent to and from the Arduino board. The RX and TX LEDs on the board will streak when information is being transmitted through the FTDI chip and USB association with the PC (yet not for sequential correspondence on pins 0 and 1). A Software Serial library takes into consideration sequential correspondence on any of the Nano's advanced pins. The ATmega328 likewise bolster I2C (TWI) and SPI correspondence. The Arduino programming incorporates a Wire library to simplify utilization of the I2C transport. To utilize the SPI correspondence, it would be ideal if you see ATmega328 datasheet

**e) Programming:**

The Arduino Nano can be customized with the Arduino programming .Select "Arduino Nano w/ATmega328" from the Tools > Board menu (as per the microcontroller on your board). The ATmega328 on the Arduino Nano comes preburned with a boot loader that enables you to transfer new code to it without the utilization of an outer equipment developer. It conveys utilizing the first STK500 convention. You can likewise sidestep the boot loader and program the microcontroller through the ICSP (In-Circuit Serial Programming) header utilizing Arduino ISP or comparable.

**f) Automatic (Software) Reset:**

Rather than requiring a physical press of the reset catch before a transfer, the Arduino Nano is planned in a way that enables it to be reset by programming running on an associated PC. One of the equipment stream control lines (DTR) of the FT232RL is associated with the reset line of the ATmega328 by means of a 100 nano farad capacitor. At the point when this line is declared (taken low), the reset line drops sufficiently long to reset the chip. The Arduino programming utilizes this capacity to enable you to transfer code by basically squeezing the transfer catch in the Arduino condition. This implies the boot loader can have a shorter timeout, as the bringing down of DTR can be very much planned with the beginning of the transfer. This setup has different implications. At the point when the Nano is associated with either a PC running Mac OS X or Linux, it resets each time an association is made to it from programming (through USB). For the accompanying half-second or so, the boot loader is running on the Nano. While it is modified to overlook contorted information (for example anything other than a transfer of new code), it will catch the initial couple of bytes of information sent to the board after an association is opened. On the off chance that a portray running on the load up gets one-time design or other information when it first begins, ensure that the product with which it conveys holds up a second in the wake of opening the association and before sending this information.

**B. Em 18 Receiver Module**

The module emanates 125 K hz through its curls and when a 125KHz uninvolved RFID tag is brought into this field it will get empowered from this field. These latent RFID labels for the most part comprise of CMOS IC EM4102 which can get enough power for its working from the field produced by the per user. This module specifically associates with any microcontroller UART or through a RS-232 converter to PC. It gives UART/Wiegand26 yield. This RFID Reader Module works with any 125 KHz RFID labels

• **Determinations: -**

- 5VDC through USB (External 5V supply will support scope of the module)
- Current: <50mA Operating Frequency: 125 K hz
- Peruse Distance: 10cm
- Size of RFID per user module: 32mm (length) \* 32mm (width) \* 8mm (tallness)

**C. Arduino Software:-**

The Arduino Integrated Development Environment - or Arduino Software (IDE) - contains a word processor for composing code, a message zone, a content support, a toolbar with catches for regular capacities and a progression of menus. It associates with the Arduino and Genuino equipment to transfer programs and speak with them. Projects composed utilizing Arduino Software (IDE) are called representations. The message region gives input while sparing and trading and furthermore shows blunders. The reassurance shows content yield by the Arduino Software (IDE), including total blunder messages and other data. The base right hand corner of the window shows the designed board and sequential port. The toolbar catches enable you to confirm and transfer programs, make, open, and spare portrays, and open the sequential screen.

**Connection Diagram**

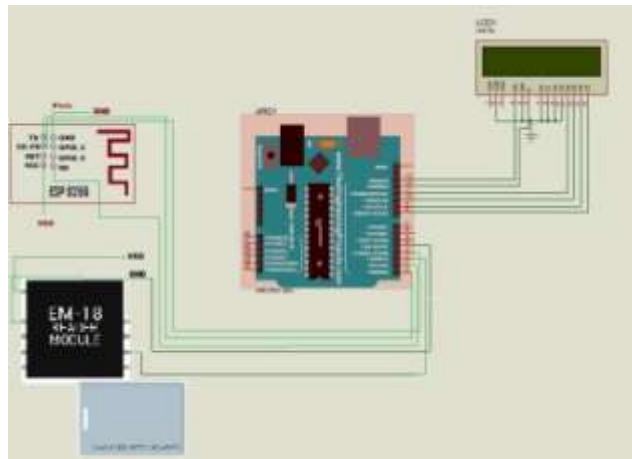

**Snap Shot:-**





#### Advantages:-

- RFID Provides area to the peruser alongside its ID.
- RFID Technology is flexible in nature and thus littler and bigger RFID gadgets are accessible according to application.
- Labels can be perused just as read/compose not at all like standardized identifications.
- The innovation can be utilized for security and participation reason in schools, universities just as office foundations. The time in and time out is recorded in the database of the server.
- Precise and Timely personnel area to organization and the executives.
- Programmed area information Collection
- Day by day Attendance Register.
- Workforce area Data Collection and writing about website page.
- Time and Energy sparing of understudies and resources.

#### Future Scope:-

There is likewise probability of utilizing RFID Tracking System in medical clinics for patients, guests and staff checking, in automobile industry, fabricating, military, transportation and so on.

#### IV. Conclusion

RFID based security and access control system is more secure and fast responded as compared to the other system like biometric. The advantage of the RFID system is contact-less and works without-line-of-sight. By using arduino it is easy to access and works very quickly while burning the code it is like plug and play device. Users can change the function accordingly by using arduino. It is easier to use and accurate also. Hence this project can be useful for implementation of access control application for tracking system as well as providing the security benefits. This project can improve by raising the range of reader in which the tag read.

#### References

- [1]. K. Finkenzer, RFID Handbook: Fundamentals and Applications in Contactless Smart Cards and Identification. West Sussex PO19 8SQ, England: John Wiley & Sons.
- [2]. C. Medeiros, J. Costa, and C. Fernandes, "RFID Reader Antennas for Tag Detection in Self-Confined Volumes at UHF," Antennas and Propagation Magazine, IEEE.
- [3]. Alien Technology, "RFID for Passive Asset Tracking," tech. rep.
- [4]. Alien Technology, ".NET API DEVELOPER'S GUIDE," tech. rep., Alien Technology Corporation.
- [5]. Available:
  - a. <http://www.alientechnology.com>
  - b. [www.electrosome.com](http://www.electrosome.com)
  - c. <http://www.zetcode.com/db/mysqlsharptutorial>